

## ASMF4L-HF Series

**Working Peak Reverse Voltage: 8.5 to 51 V**

**Peak Pulse Power: 400 W**

**RoHS Device**

**Halogen Free**

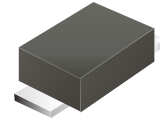

### Features

- Glass passivated chip.
- 400W peak pulse power capability with a 10/1000 $\mu$ s waveform, repetition rate (duty cycles): 0.01%.
- Low leakage.
- Excellent clamping capability.
- Very fast response time.
- ESD protection of data lines in accordance with IEC 61000-4-2.
- IEC 61000-4-2 ESD 15kV (air), 8kV (contact).
- High temperature soldering: 260°C/40 seconds at terminals.
- AEC-Q101 Qualified.

### Mechanical data

- Case: JEDEC SOD-123FL, molded plastic over glass passivated junction.
- Epoxy: UL 94V-0 rate flame retardant.
- Polarity: Color band denotes cathode end except bipolar.
- Terminal: Solderable per MIL-STD-750, method 2026.
- Mounting position: Any.

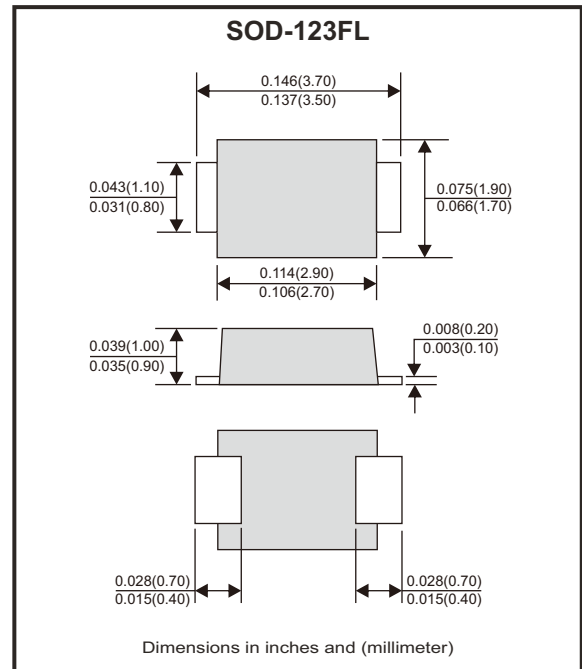

### Circuit Diagram



Bi-directional

### Maximum Ratings (T<sub>A</sub>=25°C unless otherwise noted)

Characteristics	Symbol	Value	Units
Peak power dissipation with a 10/1000 $\mu$ s waveform (Note 1)	P <sub>PP</sub>	400	W
Peak pulse current with a 10/1000 $\mu$ s waveform (Note 1)	I <sub>PP</sub>	See next table	A
Power dissipation on infinite heatsink at T <sub>L</sub> = 50°C	P <sub>D</sub>	1.0	W
Peak forward surge current, 8.3 ms single half sine-wave unidirectional only (Note 2)	I <sub>FSM</sub>	30	A
Max. instantaneous forward voltage at 25A for unidirectional only	V <sub>F</sub>	3.5	V
Operating junction and storage temperature range	T <sub>J</sub> , T <sub>STG</sub>	-55 to +150	°C

Notes: 1. Non-repetitive current pulse, per Fig.5 and derated above T<sub>a</sub>=25°C per Fig.1 .

2. Measured on 8.3 ms single half sine-wave or equivalent square wave, duty cycle = 4 pulses per minute maximum.

## Electrical Characteristics (TA=25°C unless otherwise noted)

Part No	Breakdown voltage V <sub>BR</sub> @ I <sub>T</sub>			Maximum reverse leakage @V <sub>RWM</sub> I <sub>R</sub> (μA)	Working peak reverse voltage V <sub>RWM</sub> (V)	Maximum reverse surge current I <sub>PP</sub> (A)	Maximum clamping voltage @I <sub>PP</sub> V <sub>C</sub> (V)	Marking code
	Min(V)	Max(V)	I <sub>T</sub> (mA)					Bi
ASMF4L8.5CA-HF	9.44	10.4	1	20	8.5	25.7	14.4	AT
ASMF4L9.0CA-HF	10.0	11.1	1	10	9.0	24.1	15.4	AV
ASMF4L10CA-HF	11.1	12.3	1	5	10	23.5	17.0	AX
ASMF4L11CA-HF	12.2	13.5	1	1	11	22.0	18.2	AZ
ASMF4L12CA-HF	13.3	14.7	1	1	12	20.1	19.9	BE
ASMF4L13CA-HF	14.4	15.9	1	1	13	18.6	21.5	BG
ASMF4L14CA-HF	15.6	17.2	1	1	14	17.2	23.2	BK
ASMF4L15CA-HF	16.7	18.5	1	1	15	16.4	24.4	BM
ASMF4L16CA-HF	17.8	19.7	1	1	16	15.4	26.0	BP
ASMF4L17CA-HF	18.9	20.9	1	1	17	14.5	27.6	BR
ASMF4L18CA-HF	20.0	22.1	1	1	18	13.7	29.2	BT
ASMF4L20CA-HF	22.2	24.5	1	1	20	12.3	32.4	BV
ASMF4L22CA-HF	24.4	26.9	1	1	22	11.3	35.5	BX
ASMF4L24CA-HF	26.7	29.5	1	1	24	10.3	38.9	BZ
ASMF4L26CA-HF	28.9	31.9	1	1	26	9.5	42.1	CE
ASMF4L28CA-HF	31.1	34.4	1	1	28	8.8	45.4	CG
ASMF4L30CA-HF	33.3	36.8	1	1	30	8.3	48.4	CK
ASMF4L33CA-HF	36.7	40.6	1	1	33	7.5	53.3	CM
ASMF4L36CA-HF	40.0	44.2	1	1	36	6.9	58.1	CP
ASMF4L40CA-HF	44.4	49.1	1	1	40	6.2	64.5	CR
ASMF4L43CA-HF	47.8	52.8	1	1	43	5.8	69.4	CT
ASMF4L45CA-HF	50.0	55.3	1	1	45	5.5	72.7	CV
ASMF4L48CA-HF	53.3	58.9	1	1	48	5.2	77.4	CX
ASMF4L51CA-HF	56.7	62.7	1	1	51	4.9	82.4	CZ

Notes: 1. Suffix A denotes 5% tolerance device.  
 2. For Bi-directional devices, use suffix CA.

## Rating and Characteristic Curves (ASMF4L-HF Series)

Fig.1 - Pulse Derating Curve

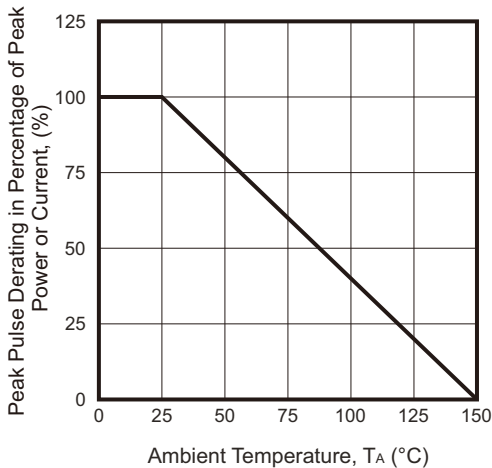

Fig.2 - Max. Non-repetitive Surge Current

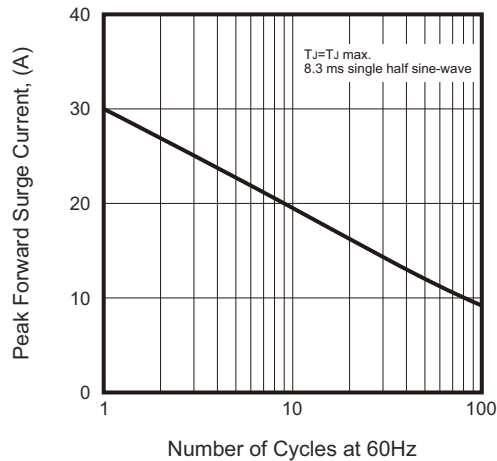

Fig.3 - Typical Junction Capacitance

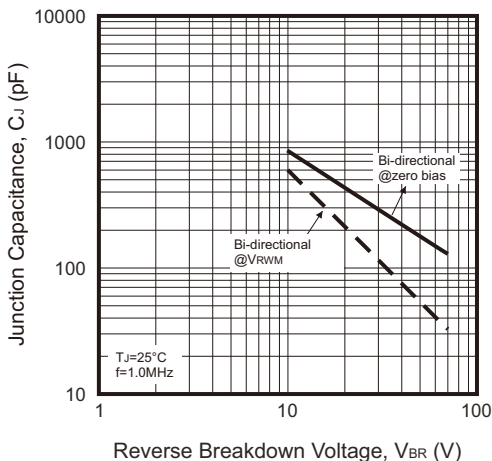

Fig.4 - Peak Pulse Power Rating Curve

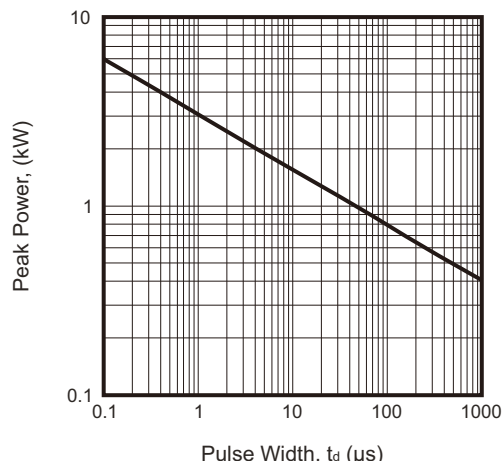
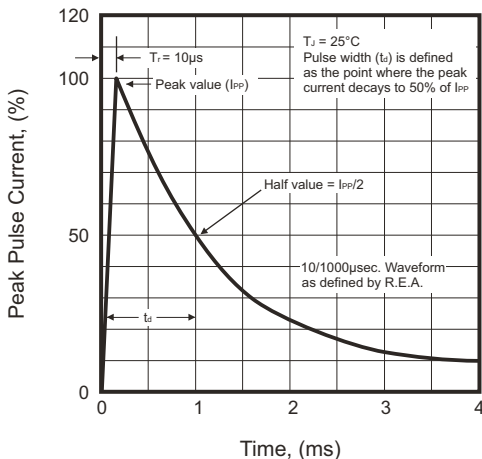
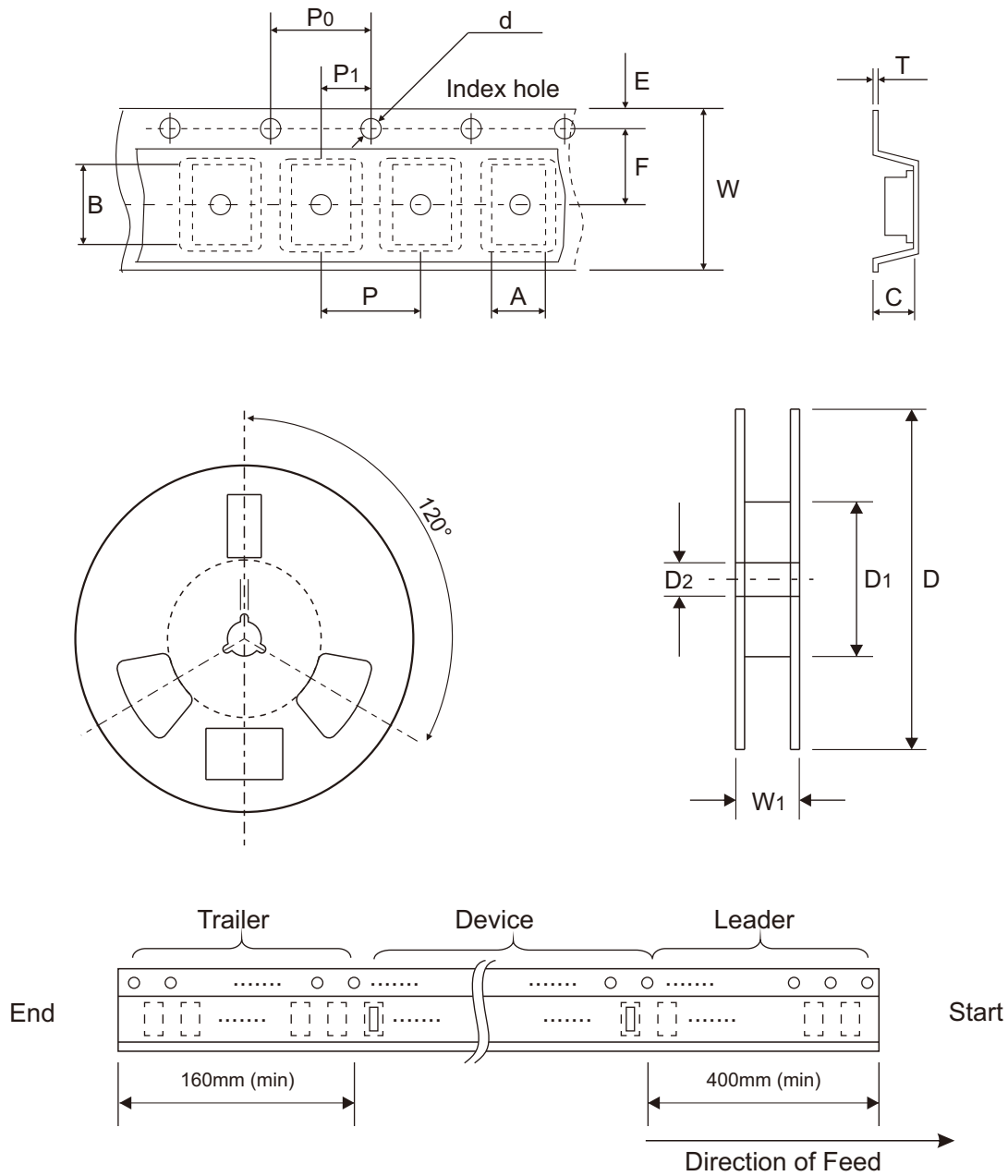

Fig.5 - Pulse Waveform



## Reel Taping Specification



SOD-123FL	SYMBOL	A	B	C	d	D	D1	D2
	(mm)	2.05 ± 0.10	3.85 ± 0.10	1.25 ± 0.10	1.55 ± 0.05	178.00 ± 1.00	60.00 ± 0.50	13.50 ± 0.50
	(inch)	0.081 ± 0.004	0.152 ± 0.004	0.049 ± 0.004	0.061 ± 0.002	7.008 ± 0.039	2.362 ± 0.020	0.531 ± 0.020

SOD-123FL	SYMBOL	E	F	P	P0	P1	T	W	W1
	(mm)	1.75 ± 0.10	3.50 ± 0.05	4.00 ± 0.10	4.00 ± 0.10	2.00 ± 0.05	0.20 ± 0.05	8.00 ± 0.30	12.00 ± 0.50
	(inch)	0.069 ± 0.004	0.138 ± 0.002	0.157 ± 0.004	0.157 ± 0.004	0.079 ± 0.002	0.008 ± 0.002	0.315 ± 0.012	0.472 ± 0.020

## Marking Code

Part Number	Marking Code
ASMF4L-HF Series	See Page 2



xx = Product type marking code (See Page 2)

## Suggested P.C.B. PAD Layout

SIZE	SOD-123FL	
	(mm)	(inch)
A	3.10	0.122
B	1.15	0.045
C	1.25	0.048
D	4.25	0.167
E	1.95	0.077

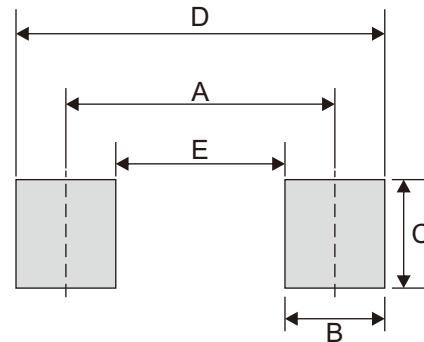

## Standard Packaging

Case Type	REEL PACK	
	REEL ( pcs )	Reel Size (inch)
SOD-123FL	3,000	7